

EVA JENSEN DESIGN

Connecting People with Culture & Nature

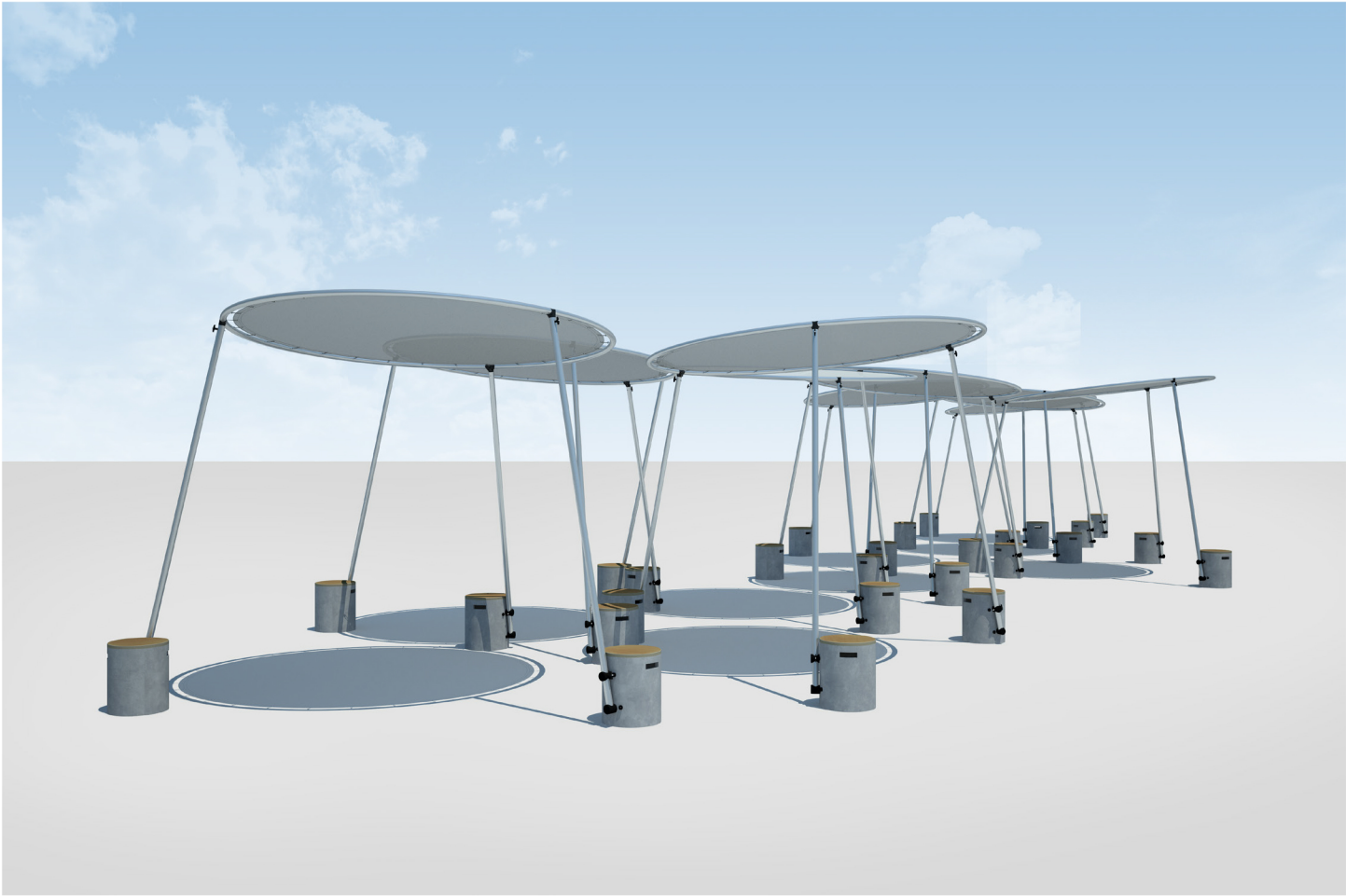

Open Spaces, Seats & Circle Shades beneath the Canopies

Circle Shade

Patented Award-Winning Design Portable Canopy System w/ Integrated Outdoor Furniture



Livable

Circle Shade offers open space beneath the canopy with unobstructed views. It integrates outdoor furniture, and the counterweights serve as seat, back rest, table top and step stool during assembly. The name captures the shape of the canopy and the function it serves

Renewal

Circle Shade synthesizes renewal of current shade structures and portable tent concepts. It eliminates the center pole of traditional parasols, opening and closing maintenance of an umbrella, and offers an alternative to square tents with integrated counterweight design.

Refined

Circle Shade is a refined canopy system based on the fundamental geometries of circle and triangle. These shapes define the design DNA in form through detail. The simple sculptural structure is articulated as a dichotomy between the lightness of the canopy and the sturdiness of the counterweights.

Versatile

The canopy system is designed for use in both the public and private realm; parks and gardens, as well as pool side and water front. In clusters Circle Shade forms a variation of dynamic sculpted spaces in open constellation for hosting a variation of events for living, entertaining and community.

Distilled

Circle Shade is a portable canopy system, circular and non-directional, and sets up as single or multiple units. It is based on the tripod structural concept and consist of three (3) main components and only seven (7) parts: 1 circular canopy, 3 poles and 3 cylindrical counterweights.

Meticulous

Circle Shade is a thoughtful design with structural engineered connections and meticulous detailing, joining bespoke with high-tech. The system is conceived as a mobile structure consisting of a kit of parts for quick assembly with flat-pack in mind.



Open Spaces, Seats & Circle Shades beneath the Canopies

Canopy System Kit of Parts



Dynamic Constellations



Circle Shade is a versatile canopy system consisting of three components and only seven parts. The canopy offers customization with option for logo branding display. Beneath the canopy, the Textiline Nano membrane provides protection from the sun's harmful rays.

It can be used both in the public and private realm; parks and gardens, pool side and water front as well as for kindergarten, education, corporate and retail campuses including residential parks.

The canopy system is a circular and non-directional structure. It sets up as single or multiple units and can rotate in different positions to one another. Circle Shade can be arranged in compelling clusters. In free constellations the canopy system forms a variation of dynamic and playful spaces.

Quick Step Assembly



New Portable Canopy System with Integrated Outdoor Furniture

Specifications & Dimensions

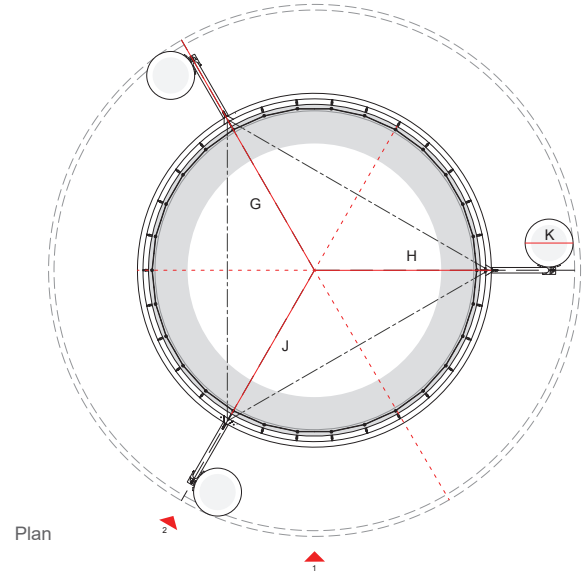
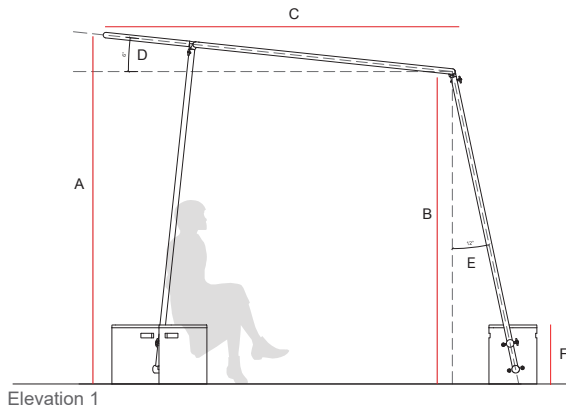

	A	B	C	D	E	F	G	H	J	K
Height	7' 9-7/8"	7'-0"				1'-4"				
Width			7'11-1/2"							
Degree				6°	12°					
Radius							6'-0"	4'-0"	3'-9"	
Diameter							12'-0"	8'-0"	7'-6"	1'-1"

Canopy membrane in Textilene Nano fabric. Canopy lacing with Hyper Ten silver HSR Dyneema UHMwPE. Stainless steel grommets and eye bolts for lacing. Quick release T-handle and Chicago screw connectors. Poles and ring segments 1-1/2" diameter aluminum tubes, option for powder coat or natural anodized finish. Joint nodes and brackets in carbon reinforced nylon or reinforced cast plastic composite. Cast concrete counterweights with fiber aggregate. Unit weight approximately 45 lbs for handling by a person.

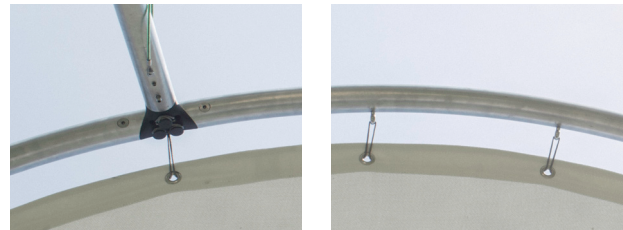

Customization Selection of options

Canopy Membrane Textilene Nano Fabrics

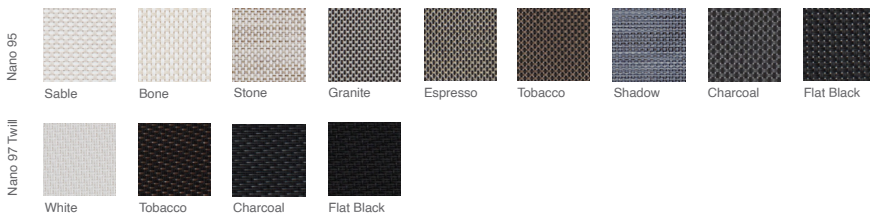

Concrete Counterweight Color options

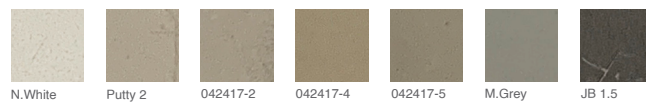

Counterweight Wood Seat options

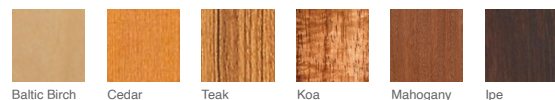

Logo branding

Customization is offered for logo design on canopy.

Material options

A range of color options are available for concrete counterweights. More upon request.

Standard wooden seat Baltic Birch. Option for upgrade.

EVA JENSEN DESIGN

Architizer A+Awards

OUTDOOR FURNITURE 2019

ARCHITECTURE + NEW MATERIALS 2020



Circle Shade